

8' Wide 10/12T (Commercial) Dump Series

Gooseneck or Tagalong

Specifications	
• G.V.W.R. - 23,900#	• Axle - (2) 10,000# Cambered Electric Brake
• G.A.W.R. (Each Axle) - 10,000#	• Suspension - Multi-Leaf Spring w/ Equalizer
• Coupler - 2-5/16" - Adjustable Gooseneck	• Tires - ST235/80R16 Load Range E
• Safety Chain - 3/8" Grade 70 w/ Hooks	• Wheel - Dually 16" 8-Bolt Grey (8 on 6.5 Pattern)
• Jack - Dual Bolt-On 10K Side Wind Drog Leg	• Deck - 3/16" 1 Piece Smooth Steel w/ Tube Frame
• Tongue - 12" I-Beam Gooseneck	• Lights - L.E.D. Stop, Tail, & Turn
• Frame - All Tubing Construction	• Vehicle Plug - 7-Way RV w/ Breakaway & SnapNSeal
• Sides - 48" 12 Ga. Smooth Steel	• Paint Prep - 5-Stage Super Blast Treatment
• Crossmembers - All Tube w/ 16" Centers	• Paint - Super Durable Powdercoat
• Fenders - Deck Over w/ Mud Flaps	• Gate - Combo: Barn Door/3-Position Spreader
• Tie Down - (4) Corner Mounted D-Rings	• Loading Option - 6' Slide-In Runner Style (Not Inc.)
<ul style="list-style-type: none"> • Hydraulic Pump - 12-Volt Self-Contained Unit w/ Remote and Inline Truck Charger • Hydraulic Lifting Hoist - Scissor Hoist: 5" Cylinder w/ Gravity Down Vent Port 	

Dump Trailers

Optional Features	
• Brake/Axle Options	• Battery Charger Options
• Hyd. Pump/Tarp Options	• TieDown/Jack Options

Dimensions						
Weight/Length	A	B	C(GN)	C(TA)	D	E
7,200# - 16'	192"	129"	102"	40"	41.5"	96"
7,600# - 18'	216"	141"	102"	40"	41.5"	96"
8,000# - 20'	240"	153"	102"	40"	41.5"	96"

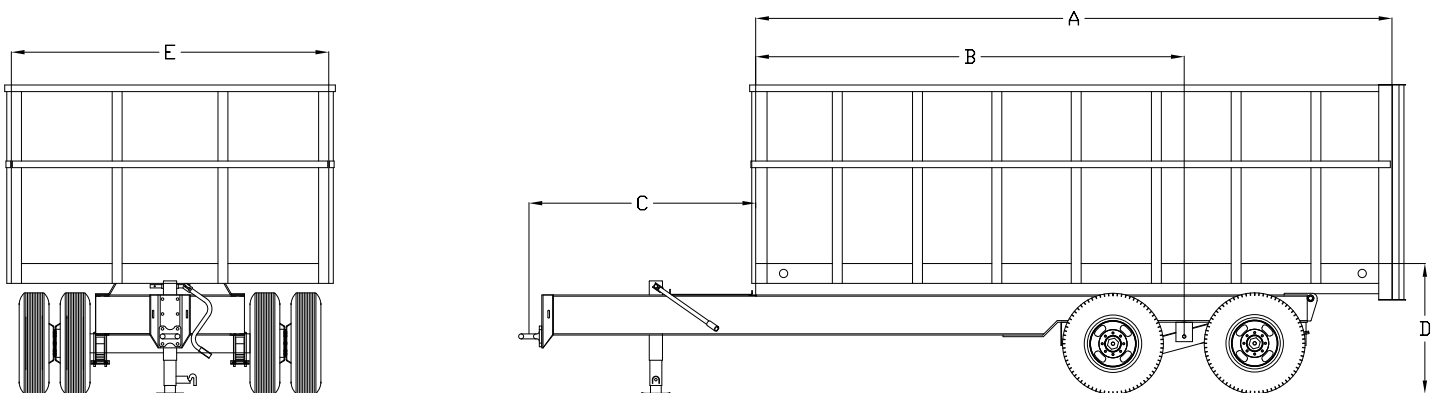

F17