

# SS (Solid Side) Utility Series

Specifications	
• G.V.W.R. - 2,900#	• Axle - (1) 3,500# Cambered EZ-Lube Idler
• G.A.W.R. (Each Axle) - 3,500#	• Suspension - Multi-Leaf Double-Eye Spring
• Coupler - 2" - Adjustable Bolt-On	• Tires - ST205/75R15 Load Range C
• Safety Chain - 3/16" Grade 30 w/ Hooks	• Wheel - 15" 5-Bolt White Spoke (5 on 4.5 Pattern)
• Jack - 2K Top-Wind Pole	• Deck - 2" Pressure Treated Pine w/ D-Rings
• Tongue - 4x3x1/4" Angle	• Lights - L.E.D. Stop, Tail, & Turn
• Frame - 3x2x3/16" Angle	• Vehicle Plug - 4-Way Flat w/ SnapNSeal Harness
• Crossmembers - 3x2x3/16" Angle w/ 24" Centers	• Paint Prep - 5-Stage Super Blast Treatment
• Top Rail - 1x2" 11 Ga. Tube w/ Spare Mount	• Paint - Super Durable Powdercoat
• Sides - 1x2" 11 Ga. Tube w/ 2' V-Panels	• Gate - 4' Swing-Down w/ CNC Machined Pins
• Fenders - 9x32" - Roll Formed w/ Steel Backs	• Gate Lock - CNC Machined Lockable Pin Latch
*Bumper - 2x4" 14Ga. CNC Laser Tubed w/ Concealed Tag Mount & Integrated EZ-Shock Gate Assist*	

Optional Features	
• Bolt-On Coupler Upgrades	• Multiple Wheel Options
• Brake Axle Upgrades	• 3K Swing-Up Jack

Dimensions					
Weight/Length	A	B	C	D	E
990# - 5x10'	120"	69.5"	21.5"	20"	60"
1,140# - 5x12'	144"	86.5"	21.5"	20"	60"
1,290# - 5x14'	168"	98.5"	21.5"	20"	60"
1,160# - 6x10'	120"	69.5"	21.5"	20"	76"
1,225# - 6x12'	144"	86.5"	21.5"	20"	76"
1,350# - 6x14'	168"	100"	21.5"	20"	76"
* 7' Wide Models Only - E=82" & 75# Added to 6' Wide Models*					

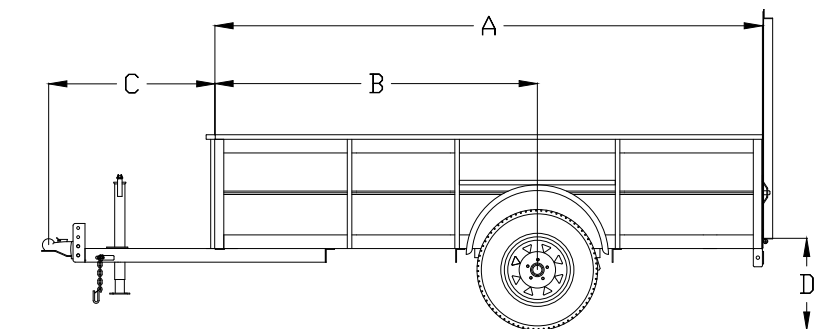
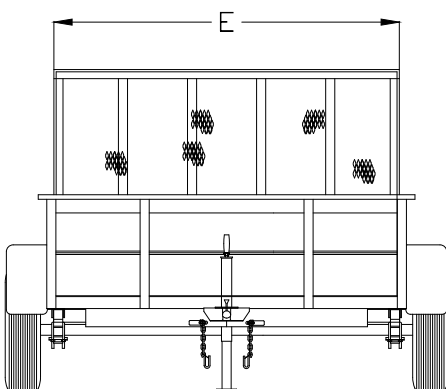

A9