

5T Equipment Series

Equipment Trailers

Specifications	
• G.V.W.R. - 9,950#	• Axle - (2) 5,200# Cambered Electric Brake
• G.A.W.R. (Each Axle) - 5,200#	• Suspension - Multi-Leaf Spring w/ Equalizer
• Coupler - 2-5/16" - Adjustable Type	• Tires - ST225/75R15 Load Range D
• Safety Chain - 3/8" Grade 43 w/ Hooks	• Wheel - 15" 6-Bolt White Spoke (6 on 5.5 Pattern)
• Jack - Bolt-On 7K Top Wind Droq Leg	• Deck - 2" Pressure Treated Pine
• Tongue - Wrapped 6" Channel	• Lights - L.E.D. Stop, Tail, & Turn
• Frame - 6" Channel (8" Channel on 22'+)	• Vehicle Plug - 7-Way RV w/ Breakaway & SnapNSeal
• Crossmembers - 3" Channel w/ 16" Centers	• Paint Prep - 5-Stage Super Blast Treatment
• Fenders - 9x72" - Diamond Plate w/ Steps	• Paint - Super Durable Powdercoat
• Ramps - 5' Runner Style Fold Down w/ Spring Assist & Lockable Ramp Bars	

Optional Features	
• Side & Floor Options	• Tie Down Package
• 5' Double Split Gates	• Diamond Plate Steel Floor
• Coupler & Brake Upgrades	• Spare Mount & Wheel Options

Dimensions						
Weight/Length	A	B	C	D	E	Dove
2,575# - 12'	144"	88"	46.5"	24"	82"	24"
2,625# - 14'	168"	100"	46.5"	24"	82"	24"
2,675# - 16'	192"	112"	46.5"	24"	82"	24"
2,725# - 18'	216"	124"	46.5"	24"	82"	24"
2,775# - 20'	240"	136"	46.5"	24"	82"	24"
3,050# - 22'	264"	148"	46.5"	24"	82"	24"

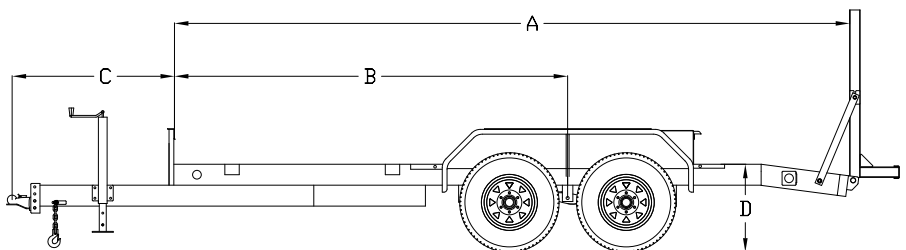
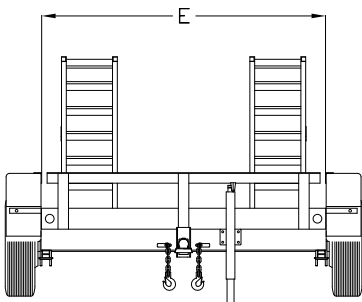

B1