

5K Dump Series

Specifications	
• G.V.W.R. - 5,200#	• Axle - (1) 5,200# Cambered Idler
• G.A.W.R. (Each Axle) - 5,200#	• Suspension - Multi-Leaf Slipper Spring
• Coupler - 2" - Adjustable Bolt-On	• Tires - ST225/75R15 Load Range D
• Safety Chain - 3/16" Grade 30 w/ Hooks	• Wheel - 15" 5-Bolt White Spoke (6 on 5.5 Pattern)
• Jack - 3K Top Wind	• Deck - 10 Ga. 1 Piece Smooth Steel w/ Tube Frame
• Tongue - Wrapped 5" Channel	• Lights - L.E.D. Stop, Tail, & Turn
• Frame - All Tubing Construction	• Vehicle Plug - 4-Way Flat w/ SnapNSeal Harness
• Sides - 24" 12 Ga. Smooth Steel	• Paint Prep - 5-Stage Super Blast Treatment
• Crossmembers - All Tube w/ 16" Centers	• Paint - Super Durable Powdercoat
• Fenders - 9x32" - Roll Formed	• Gate - #1 Solid Side Swing w/ Spreader
• Hydraulic Pump - 12-Volt Self-Contained Unit w/ Remote and Inline Truck Charger	
• Hydraulic Lifting Hoist - Single Push Rod Cylinder: 3.5x24" w/ Gravity Down Vent Port	

Optional Features	
• Tire & Brake Upgrade	• Battery Charger Options
• Honda Gas-Power Hydraulic Pump or Wet Line Hook-Ups	

Dimensions					
Weight/Length	A	B	C	D	E
1,600# - 10'	120"	67"	36"	24"	60"

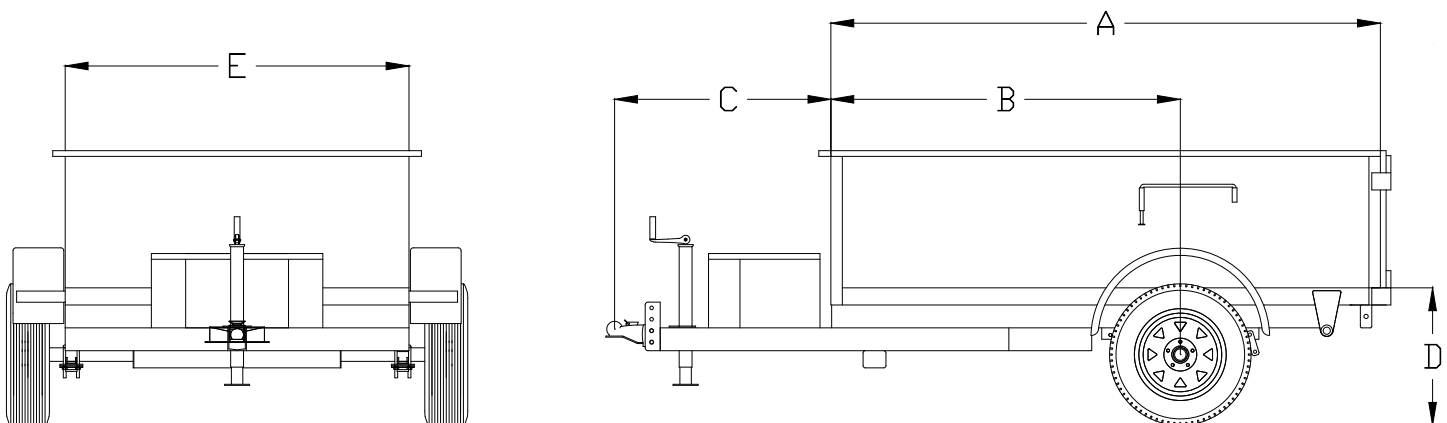

F1

Dump Trailers